



[Brake shoes, replacement](#)

[Brake cable \(older model\), replacement](#)

[Parking brake cable, replacement](#)

## Brake shoes, replacement

[115 8147](#)

### Preparations

- Remove cover panel under center console armrest.
  - Undo parking brake adjusting bolt by parking brake lever until cable goes slack.
  - Remove rear wheel.
-



### Removing brake caliper

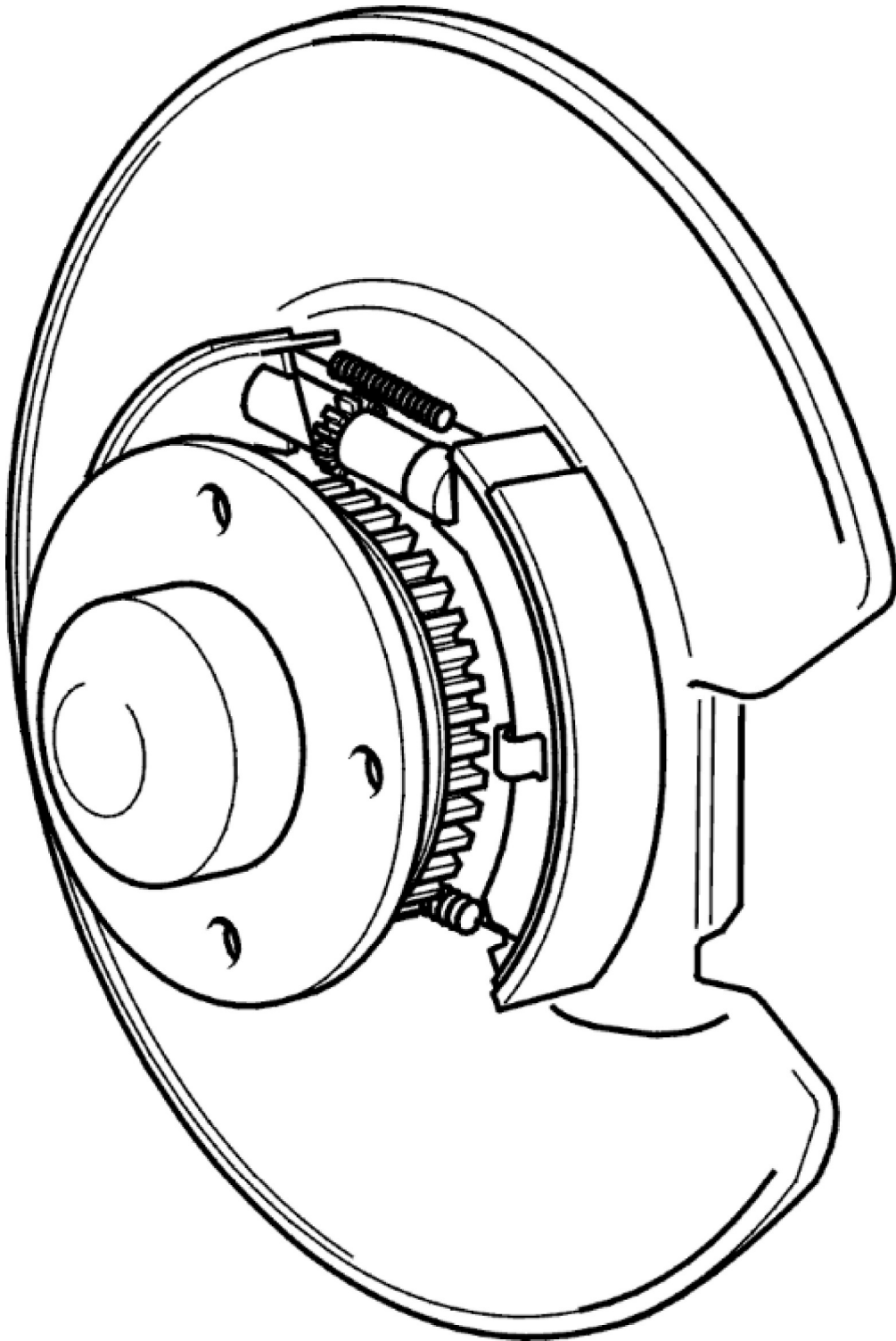



## Removing brake disc

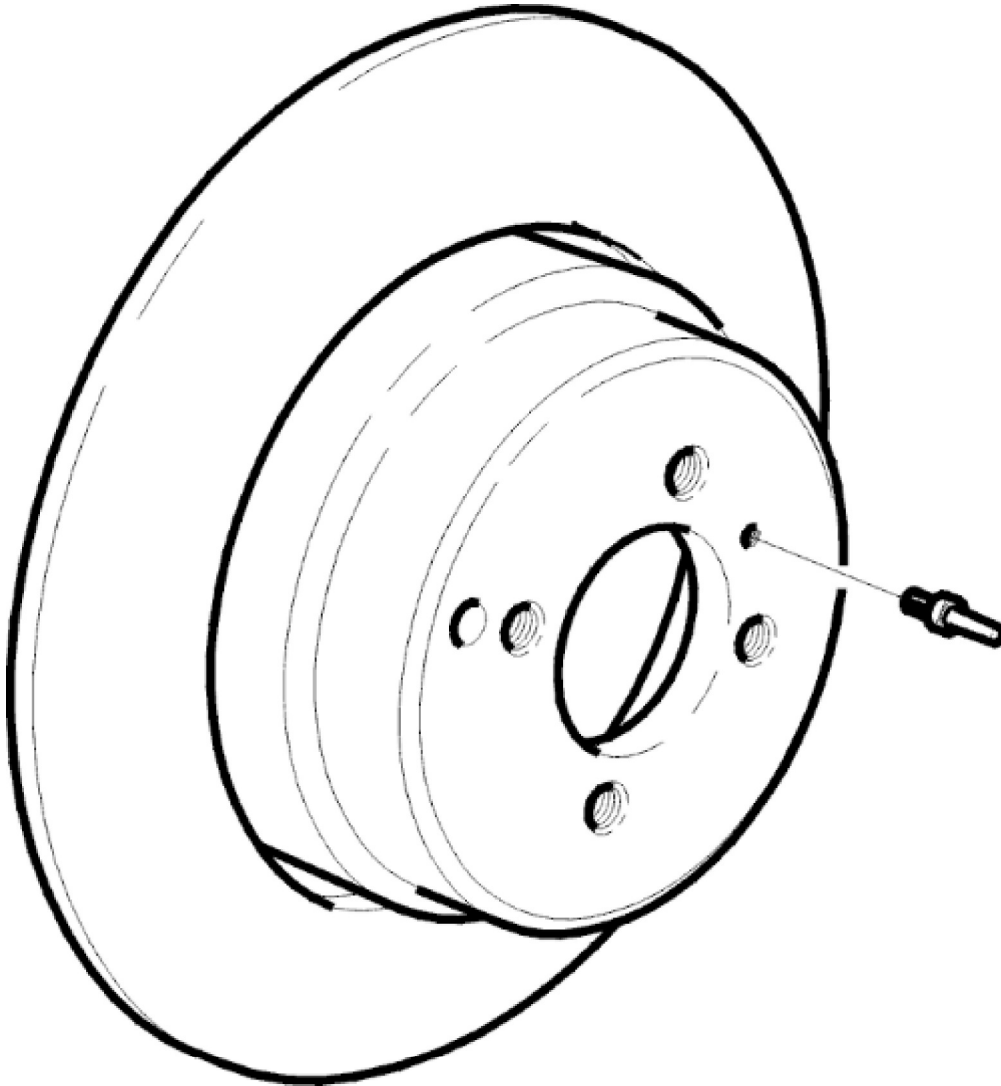

- Undo parking brake adjusting bolt until brake disc can be removed. Adjusting bolt can be accessed by turning the brake disc until the adjustment hole is centered over the adjusting bolt sitting between the brake shoes.
- Remove locating pin and mark brake disc against hub so that disc lines up properly when reinstalling.
- Remove brake disc.



### Removing brake shoes

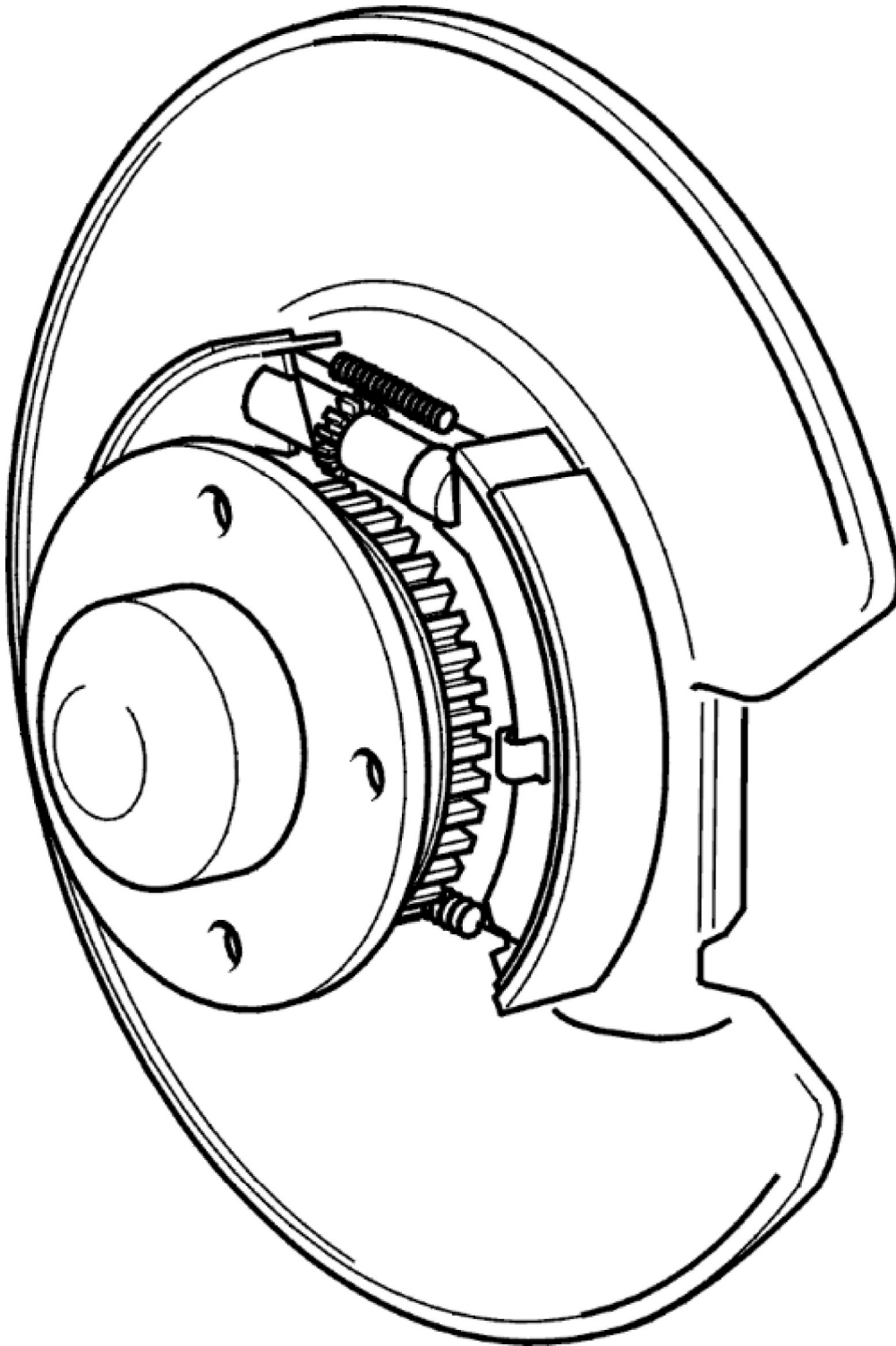



## Cleaning and checking

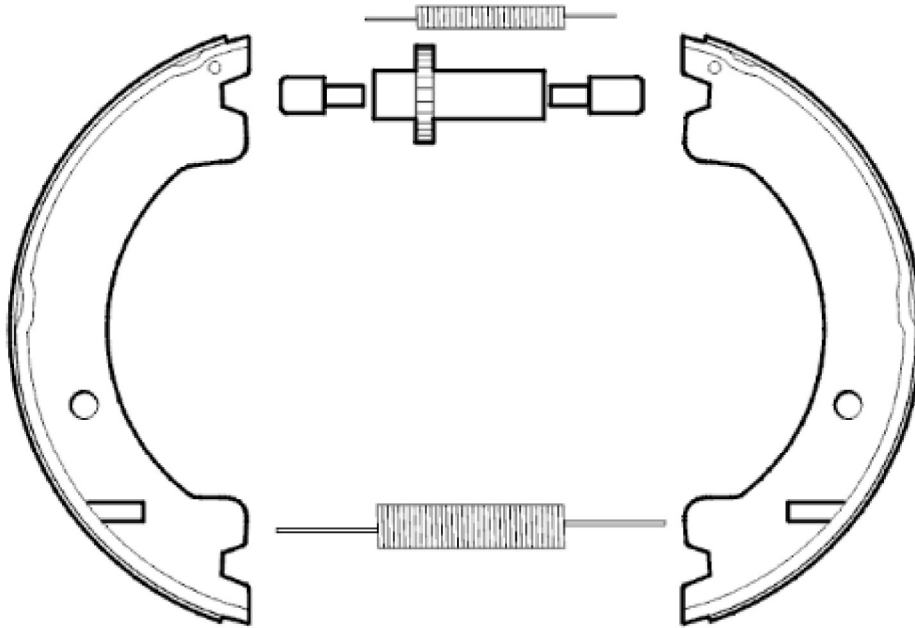

- Check that no grease leaks out of the hub.
- Check that brake arms and cables are not worn and not rubbing anywhere.
- Clean the surfaces of the brake drum where the brake shoes make contact.
- Check that the adjusting bolts turn easily on their threads.
- Grease with heat-resistant grease if necessary.
- Apply a thin layer of heat-resistant graphite grease to the sliding surfaces.

- 
- Check that hub flange is clean.
  - Remove rust with a steel blade and steel brush.
  - Brush any dirt off of wheel sensor and pulse wheel with a soft brush.
-



## Installing brake shoes

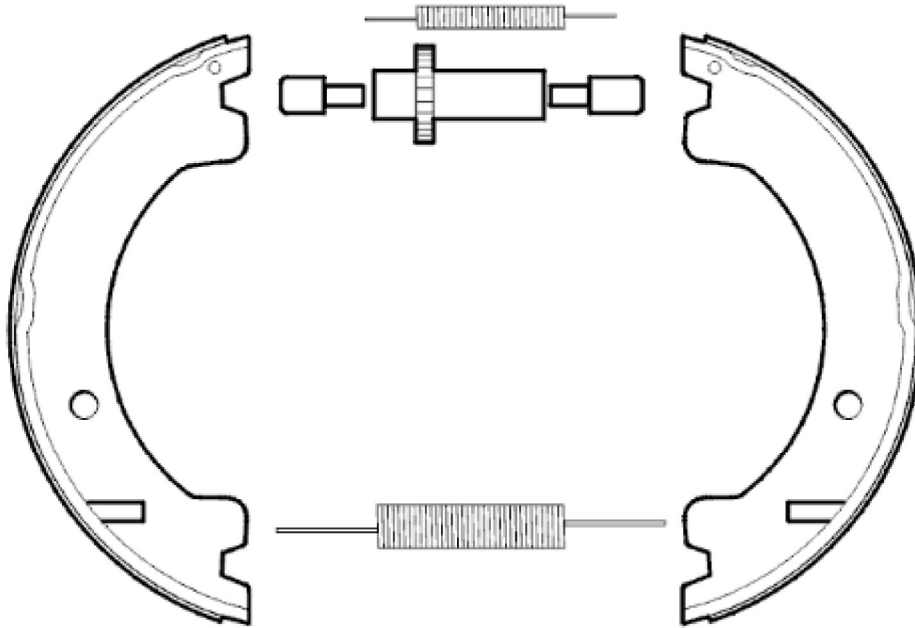

- Install brake shoes on hub and install upper return spring.
- Check that adjusting bolts are turned correctly as per illustration. Illustration is looking from outside.



## Installing brake disc and brake caliper

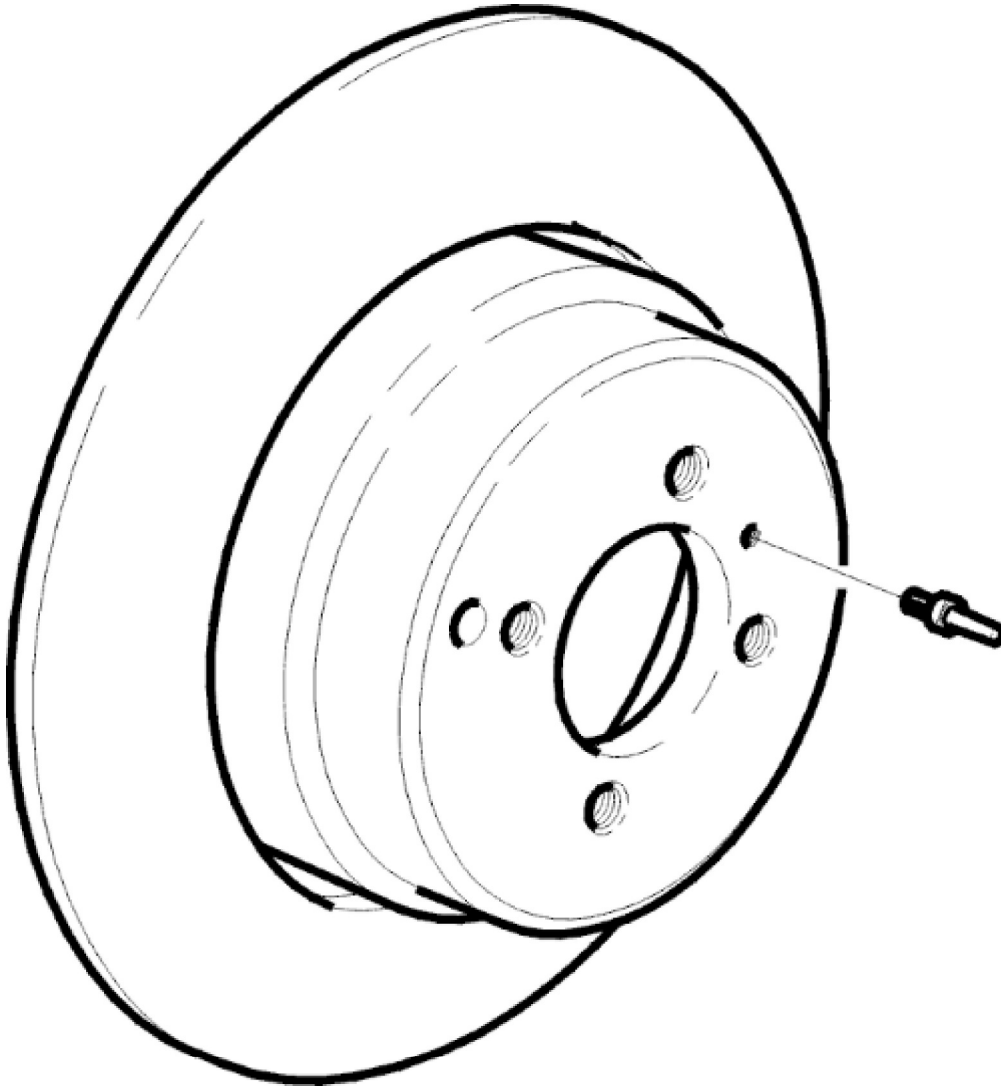

### Note!

**Be careful when handling the new brake disc. Careless handling can cause damage (e.g. warping).**

- Install brake disc on hub in line with mark on hub.
- Install locating pin and tighten to 8 Nm (6 ft.lb).
- Install brake caliper with new bolts. Tighten to 60 Nm (45 ft.lb).



- Install brake pipe in brackets.
- Install three-way connector mounting bolt, (LH brake caliper only).

---

### Adjusting parking brake

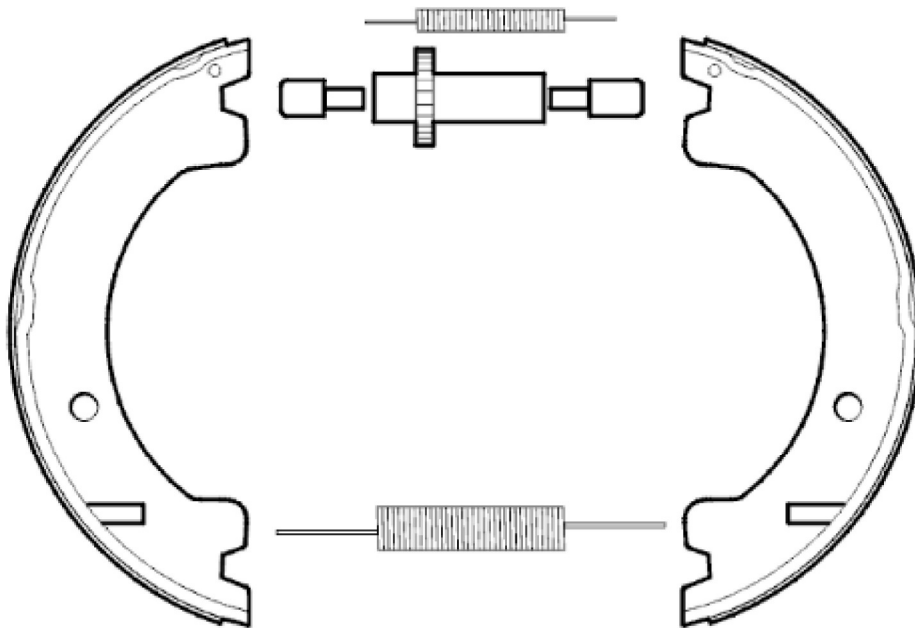

Go to [Parking brake](#) and complete procedure as per instructions there.

---